

THERMAL MASS

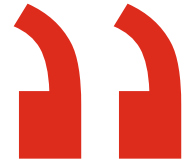

(VELOCITY FLOW METER)



THE THERMAL MASS FLOW METER OPERATES ON THE PRINCIPLE OF THERMAL DISPERSION, UTILIZING THE CONCEPT THAT GASES CONDUCT HEAT DIFFERENTLY THAN OTHER SUBSTANCES. THE METER CONSISTS OF TWO TEMPERATURE SENSORS: ONE IS A HEATED SENSOR, AND THE OTHER IS A REFERENCE SENSOR. THE HEATED SENSOR MAINTAINS A CONSTANT TEMPERATURE DIFFERENCE WITH THE REFERENCE SENSOR. AS THE GAS FLOWS THROUGH THE METER, IT COOLS THE HEATED SENSOR, AND THE FLOW RATE IS DIRECTLY PROPORTIONAL TO THE AMOUNT OF COOLING. BY MEASURING THE TEMPERATURE DIFFERENCE BETWEEN THE TWO SENSORS, THE THERMAL MASS FLOW METER CALCULATES THE GAS FLOW RATE.

ADVANTAGES

Thermal Mass Flowmeter, One of the advantages of thermal mass flow meter is that they provide direct mass flow measurements. This makes them suitable for applications where mass flow is a critical parameter. Thermal mass flow meter typically have no moving parts in contact with the fluid. This feature contributes to their reliability and reduces the need for maintenance. Thermal mass flow meter often have a high turndown ratio, allowing them to accurately measure a wide range of flow rates. This is beneficial in processes where flow rates may vary. Thermal mass flow meter are known for their fast response times, providing real-time measurements of flow rates. These flow meter generally have a low pressure drop, meaning they do not significantly impede the flow of the fluid in the pipeline.

MARKETS & AREAS OF APPLICATION

Thermal mass flow meter are primarily used for measuring the flow of gases. Common gases include air, natural gas, nitrogen, and other process gases. Thermal mass flow meter are designed to handle a variety of gases without the need for recalcitration. This versatility makes them suitable for applications where the gas composition may vary. Thermal mass flowmeter are generally known for their high accuracy, and they are often chosen for applications where precise flow data is crucial. This accuracy is particularly valuable in industries such as chemical processing, HVAC systems, and environmental monitoring.

PERFORMANCE DATA

The thermal mass flow meter is designed for a range of pipe sizes, specifically DN 15 to DN 4000. This indicates that the flow meter can be installed in pipes with nominal diameters ranging from 15 to 4000 mm. The flow meter is specified to measure flow rates within a certain range, denoted as 1 – 7,00,000 Nm³/h. This range covers a wide spectrum of flow rates, from relatively low to high, making it versatile for various applications. Thermal mass flowmeters are generally known for their high accuracy, and they are often chosen for applications where precise flow data is crucial.

GENERAL SPECIFICATION

Sensor Housing : SS - 316 / Hastelloy / PTFE Coated

Velocity : $\pm 0.1 \sim 100$ Nm/s

Accuracy (standard position): $\pm 1\%$

Fluid & Ambient Temperature : - 20 to 240 °C

Connection : Insertion Type / Flange End

DISPLAY WITH VARIOUS OUTPUT

Power Voltage : 24 V DC / 230 V AC

Output Signal

Retransmit : (4 ~ 20) mA / Pulse

Communication : RS - 485 / HART Protocol / Alarm

Relay : High & Low Flow

Battery Operated Meter

Power Voltage : 3.6 V DC Lithium Batteries

Display Mode : Double row LCD as below

Q X.XXXXXX Seven Digit Instantaneous Flow
(Nm³/h, Nm³/m, Kg/h, Kg/m, t/h, t/m, L/h, L/m, SCFM)

XXXXXX.XXXXXX Twelwe Digit Cumulative Flow

Cumulative flow : Automatically expand the display precision.

The cumulative flow values can be reset.

Power - fail protection : The instrument coefficient ensures that total flow values for the past ten years are retained even in the event of a power supply drop.

MODEL RANGE

Connection (f)	Flow rate maximum : Nm ³ /hour
15	65
25	175
32	290
40	450
50	700
65	1200
80	1800
100	2800
125	4400
150	6300
200	10000
250	17000
300	25000
400	45000
500	70000
600	100000
700	135000
800	180000
900	220000
1000	280000
1200	400000
1500	600000
2000	700000

DISPLAY OUTPUT

* Please Check Display Manual

calculate pulse/liter at : 25%, 50%, 75% and 100% flow rate with air at Atm or room pressure and temperature

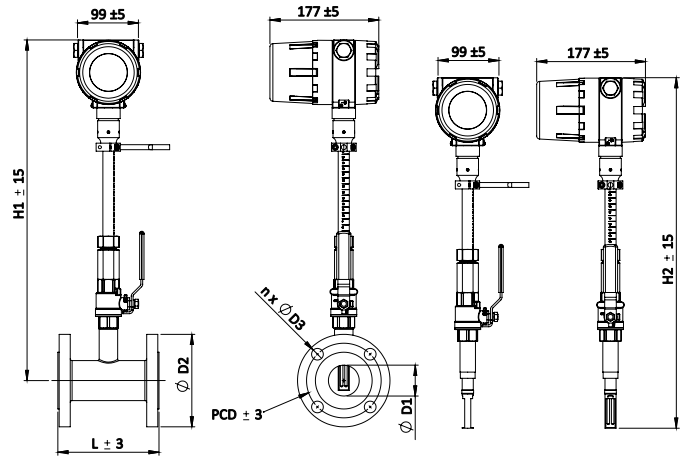

FLANGE END DIMENSION

Model Number	L	H 1	H 2	D 1	D 2	n X D 3	PCD
BT-TMFM-025	130	437	440	24	110	4 X 16	79.4
BT-TMFM-040	170	434	440	38	125	4 X 16	98.4
BT-TMFM-050	170	435	440	50	150	4 X 19	120.7
BT-TMFM-065	200	443	440	65	180	4 X 19	139.7
BT-TMFM-080	200	568	570	76	190	4 X 19	152.4
BT-TMFM-100	220	570	570	100	230	8 X 19	190.5
BT-TMFM-125	220	583	570	125	255	8 X 22.3	215.9
BT-TMFM-150	270	595	570	150	280	8 X 22.3	241.3
BT-TMFM-200	310	620	570	200	345	8 X 22.3	298.5
BT-TMFM-250	370	645	570	250	405	12 X 25.4	362.0
BT-TMFM-300	400	670	570	300	485	12 X 25.4	431.8

*"L" WILL BE CHANGE AS PER SPECIFIC REQUIREMENT

ALL THE DIMENSION IN MILIMETERS

